

Tech Tip #100

Axle Eye Bore Diameter Inspection

DO NOT INSTALL A NEW STEMCO Kaiser KINGPIN KIT WITHOUT FOLLOWING THE INSTRUCTIONS IN THIS TECH TIP. IMPROPER INSPECTION OR INSTALLATION MAY JEOPARDIZE THE KINGPIN KIT LIFE AND WARRANTY.

APPLICATION

This Tech Tip applies to the following products:

<p>Dana® Spicer® Eaton® Steer AXLES: (single locking draw key design) E-1000I (10,000#) E-1200I (12,000#), E-1201I (12,000#) E-1320I (13,200#)</p>	<p>STEMCO Kaiser KINGPIN KITS: Kingpin QWIKkit™ (K122E) Kingpin PLUSkit™ (70.122.05, 70.122.95) Kingpin ECONOkit™ (50.122.05)</p>
---	--

STEP 1. INSPECT FOR WEAR

Inspect the front axle/steering knuckle assembly for vertical play and end play (wear) per the OEM's suggested method. If a worn condition exists, proceed to Step 2. Teardown Assembly.

STEP 2. TEARDOWN ASSEMBLY

Use the established OEM procedures to teardown the axle/steering knuckle, kingpin, bushings, thrust bearing and shims. Be sure to fully remove the steering knuckle away from the front axle – exposing the axle eye bore.

STEP 3. INSPECT AXLE EYE BORE DIAMETER

Clean (wipe down) the axle eye bore. Inspect the top and bottom side of the axle eye bore using the **GO/NO-GO** tool included in the kingpin kit as follows: (refer to Figure A for illustration)

1. Hold the **GO/NO-GO** tool "in-line" with the top opening of the axle eye bore. Attempt to insert the tool into the bore. Repeat top opening inspection with the tool rotated to various positions.
2. Hold the **GO/NO-GO** tool "in-line" with the bottom opening of the axle eye bore. Attempt to insert the tool into the bore. Repeat bottom opening inspection with the tool rotated to various positions.

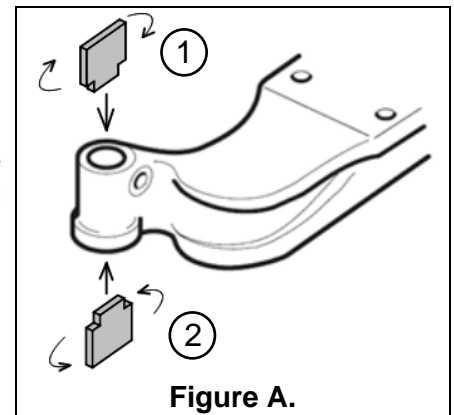

Figure A.

STEP 4. INSPECTION RESULTS

If the GO/NO-GO tool did fit into the axle eye bore to any depth, in any position,

STOP! DO NOT PROCEED!

This inspection identified an excessively worn axle eye bore. Do not install a STEMCO Kaiser kingpin kit until the axle eye bore has been serviced. Axle eye bore service may include machining and/or sleeving.

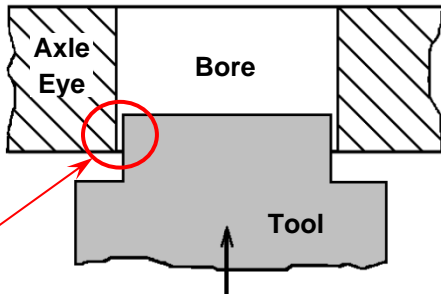

Fits into bore.

If the GO/NO-GO tool did NOT fit into the axle eye bore tool to any depth, in any position,

THE AXLE EYE BORE DIAMETER IS ACCEPTABLE.

PROCEED TO INSTALL THE NEW STEMCO KAISER KINGPIN KIT per the kit installation instructions.

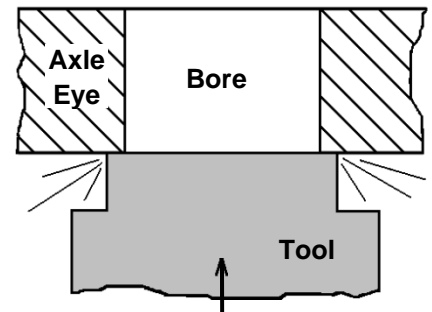

WARNING: Installing a new kingpin kit in an excessively worn axle may cause the kingpin kit to wear prematurely, reduced service life and a voided warranty.